

Motivation

Current 3D-Controllable GAN
Good Controllability on Randomly Sampled Code

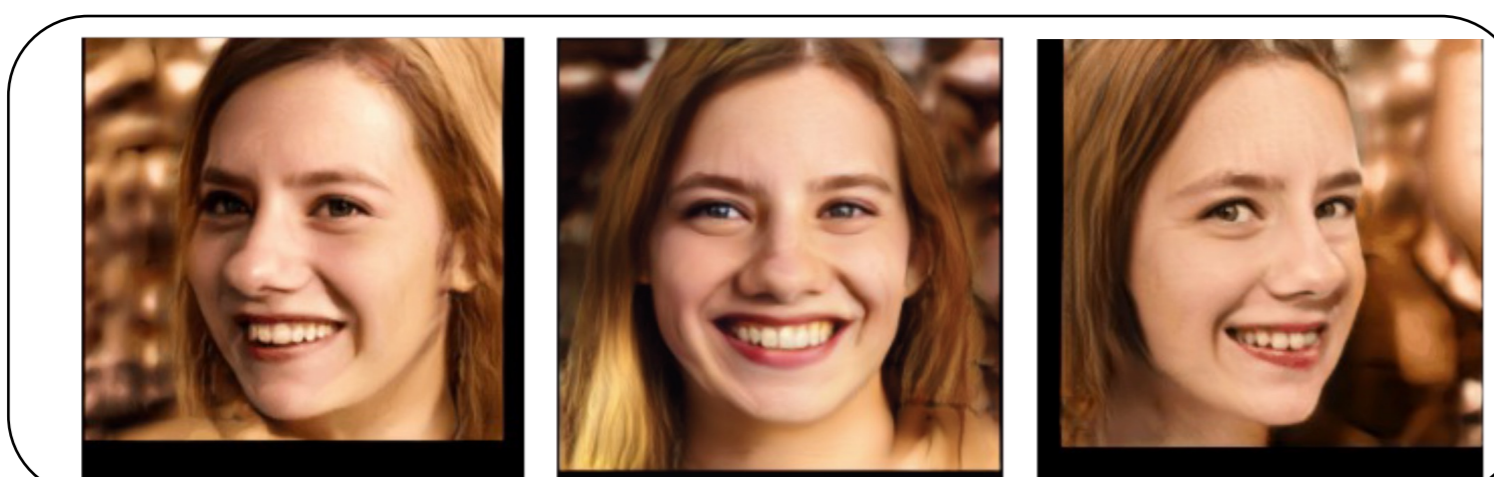

Worse Performance on Manipulating Existing Images

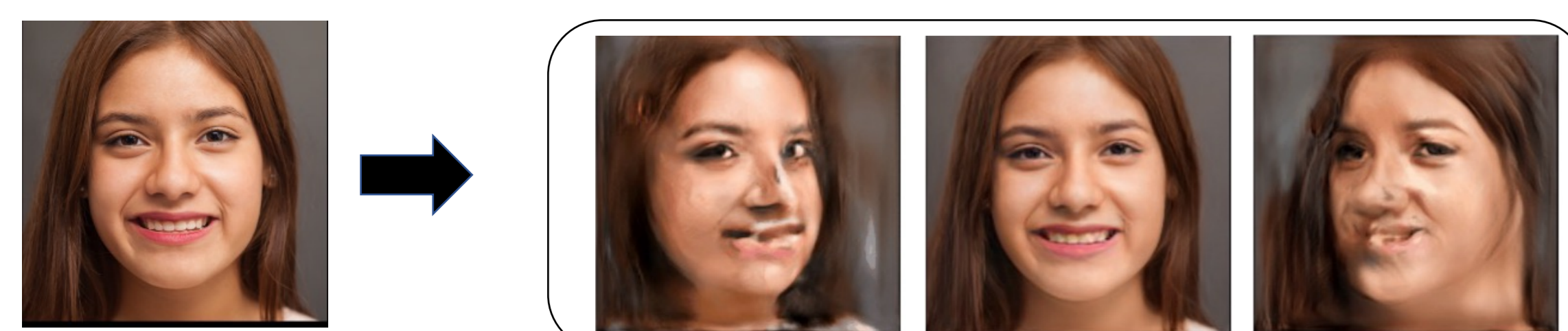

*Above results are obtained by DiscoFaceGAN

Our Approach

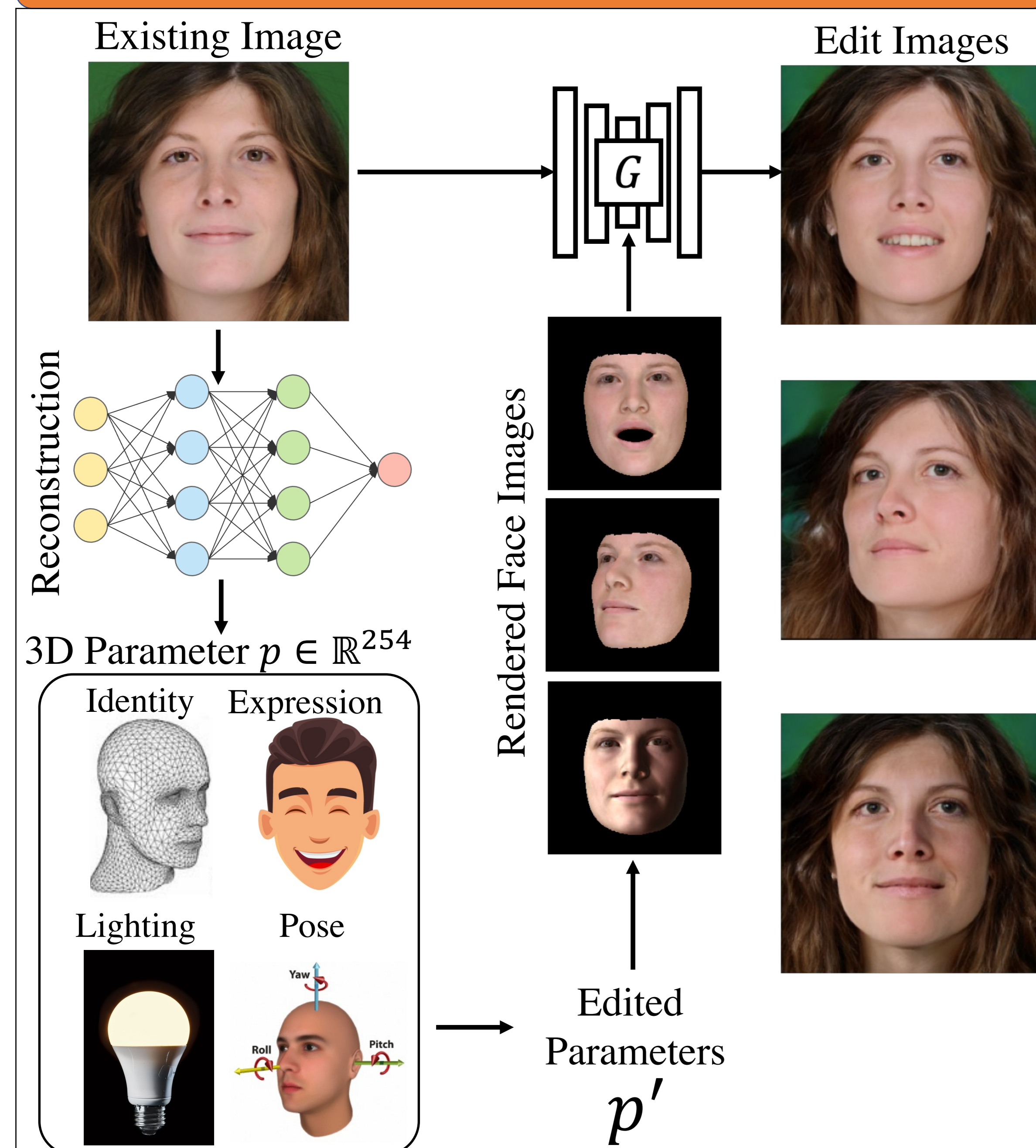

Dataset

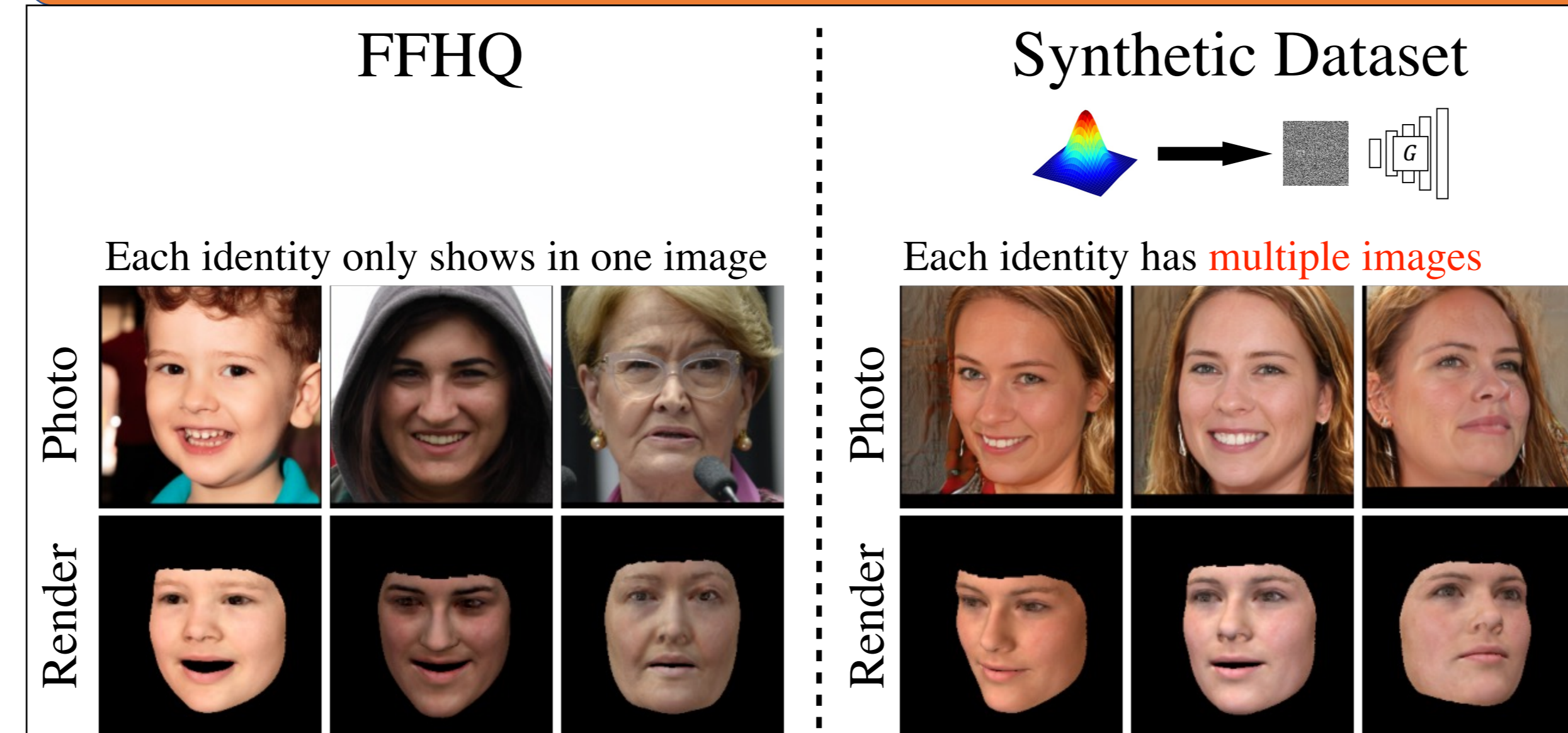

Architecture

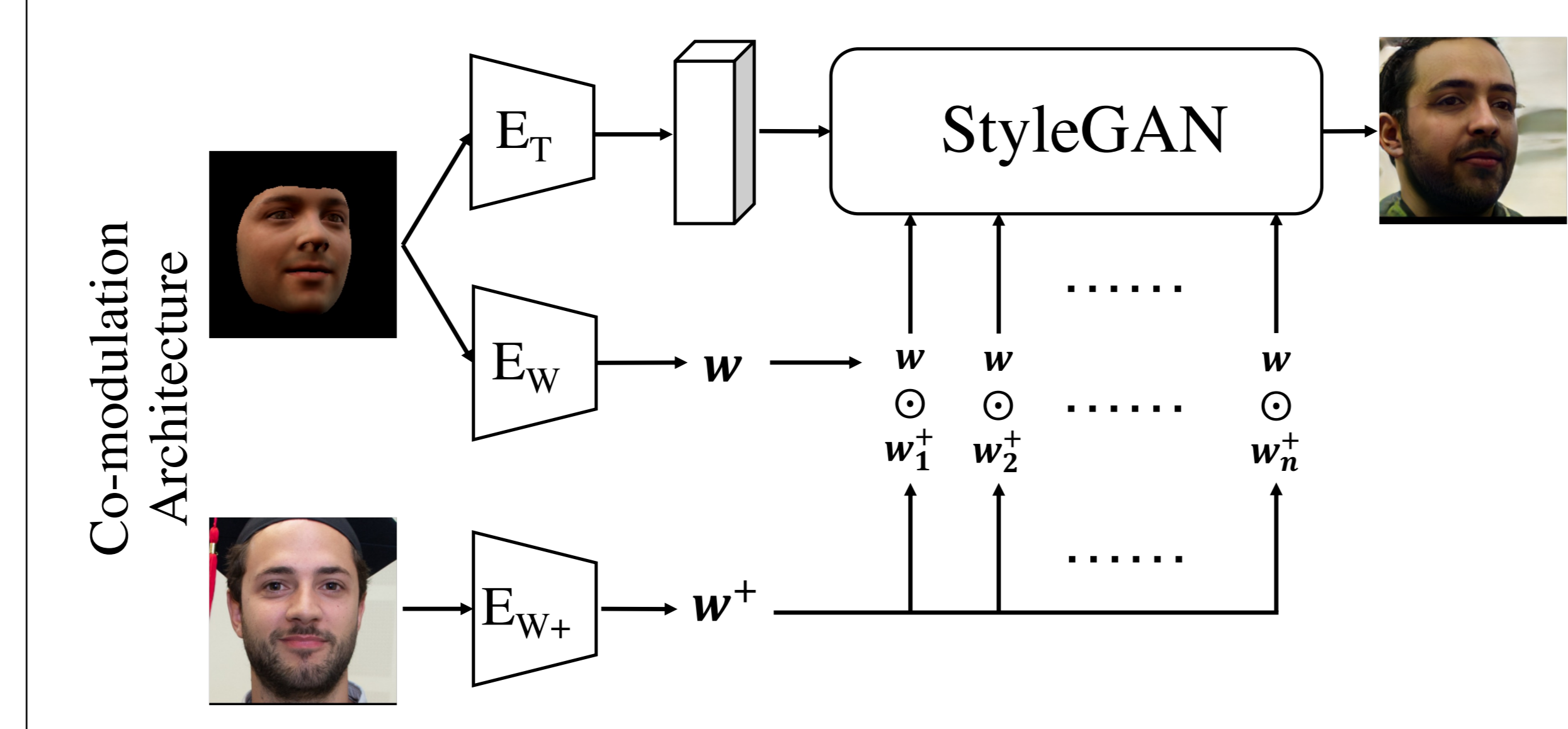

Training Scheme

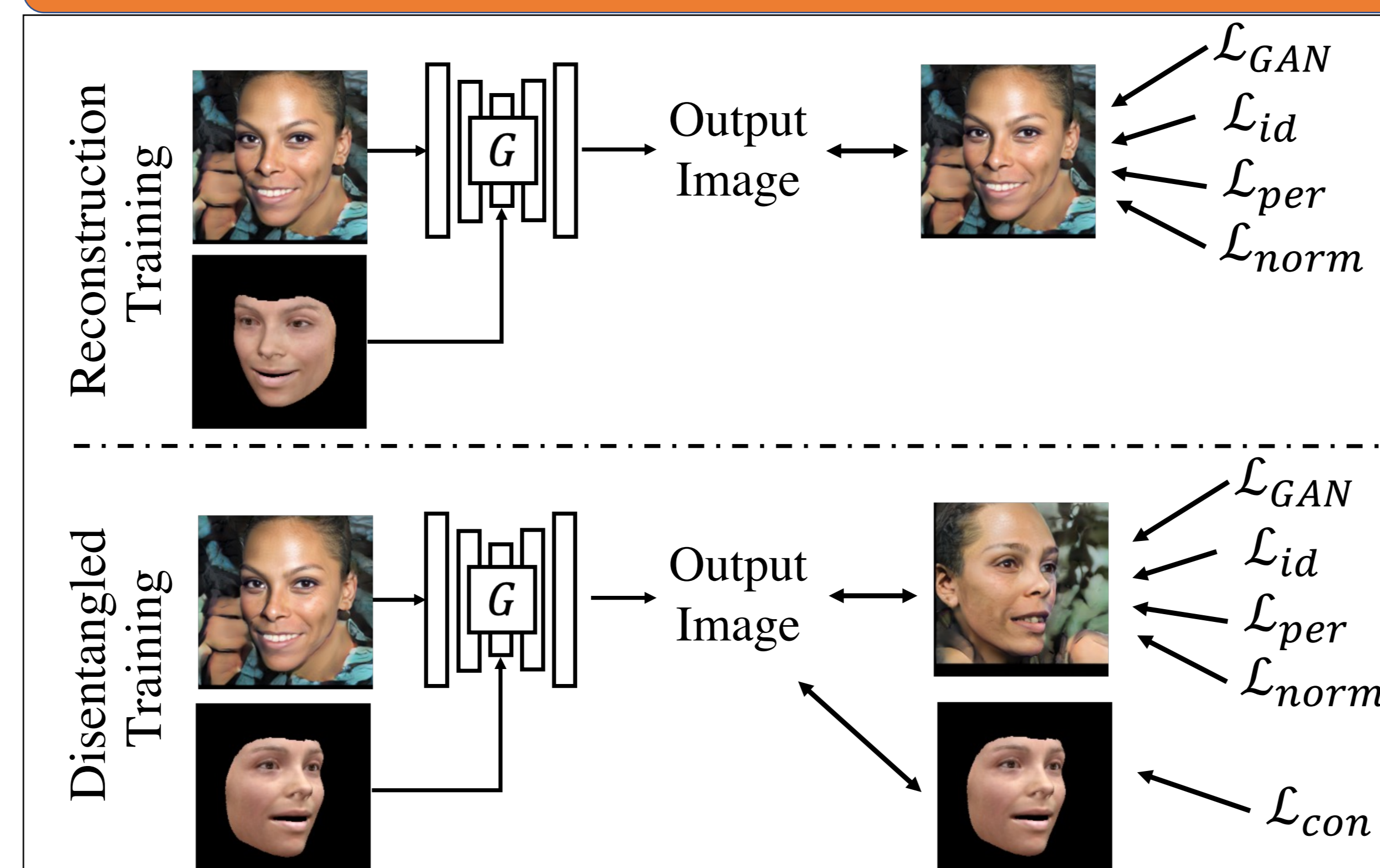

Experimental Results

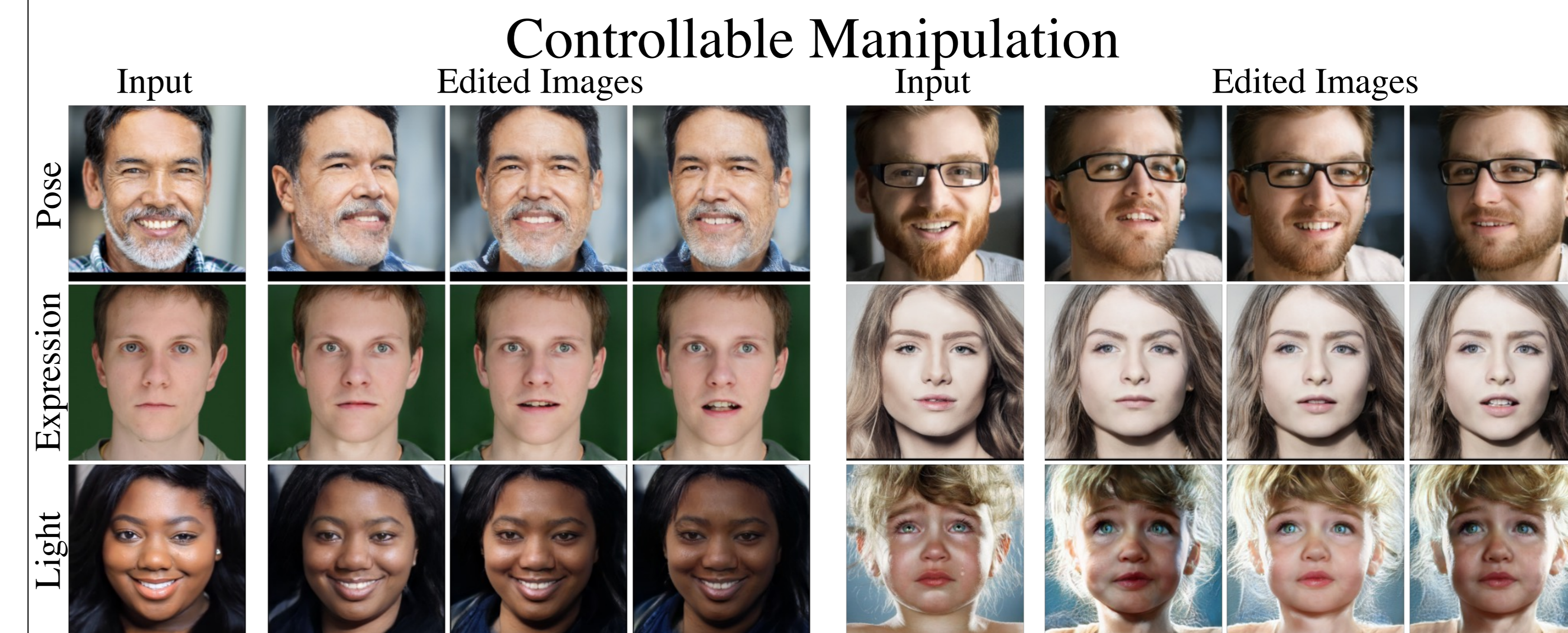

Artistic Face Editing



Reanimation

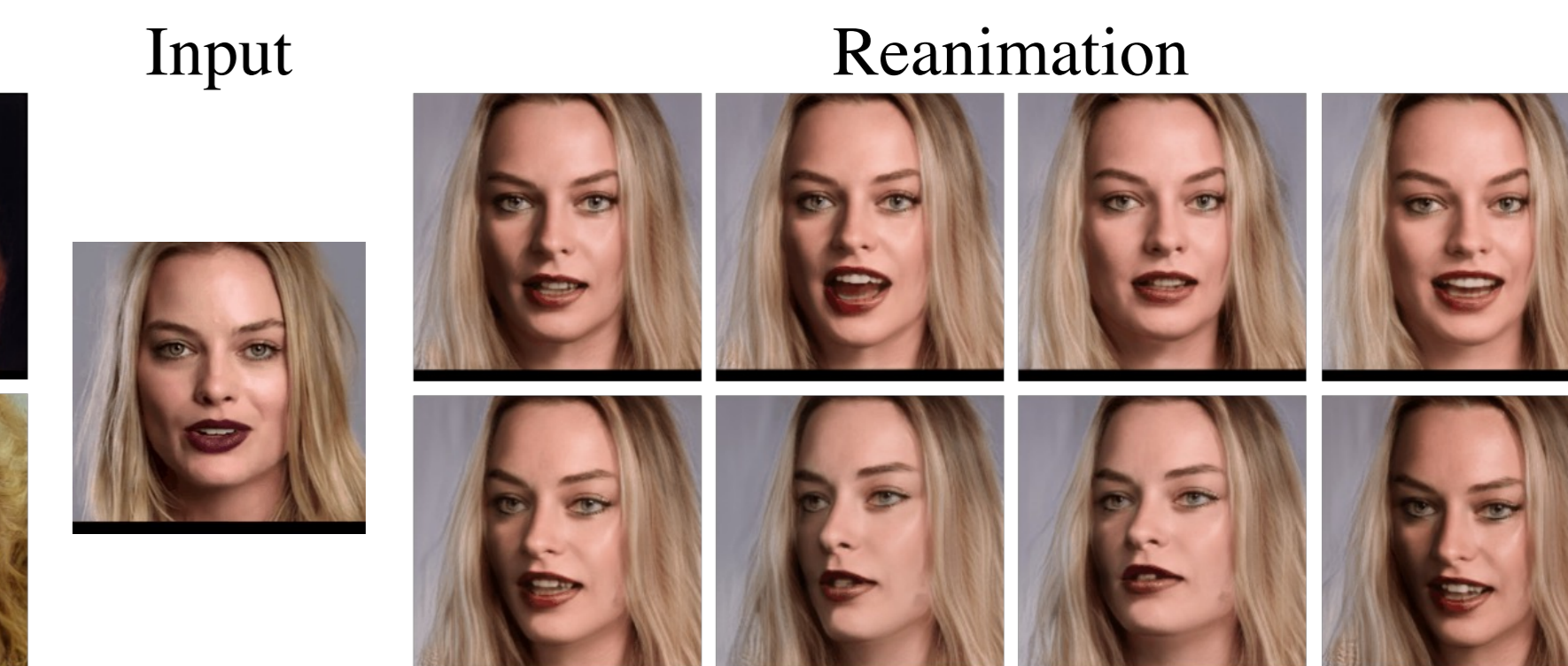

Comparing to State-of-the-Art Methods

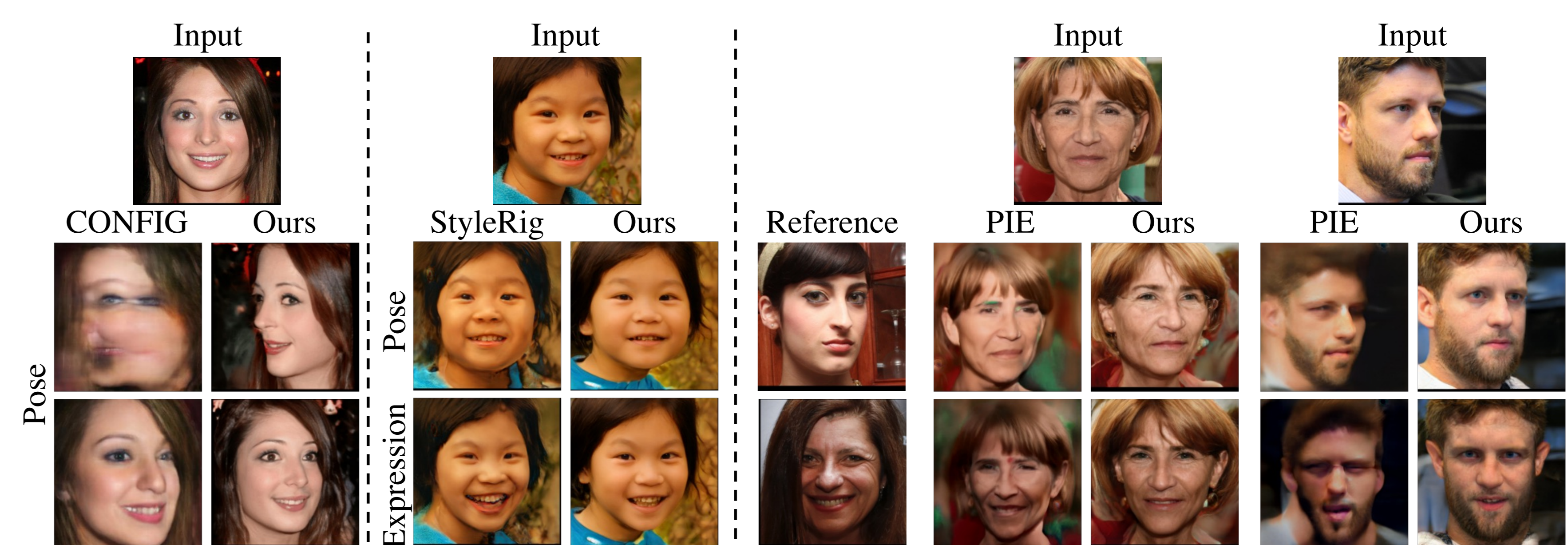

Paper Resource

Webpage: <https://lychenyoko.github.io/3D-FM-GAN-Webpage/>

Video: <https://www.youtube.com/watch?v=3tR7qIXyzLE>